



How To Make Sure Your Air Conditioner Keeps Its Cool

So you don't have to sweat out a summer of repairs

HSB, a Munich Re company, is a technology-driven company built on a foundation of specialty insurance, engineering and technology, all working together to drive innovation in a modern world.

If you're going to have an air conditioning failure, it's going to happen in the next few weeks. More air conditioning breakdowns occur during early summer than any other time.

We know. We pay the insurance claims on them. But you pay the price: In equipment downtime, repairs, and heat from the management.

That's why we're offering tips from our field inspectors: How to avoid the most common air conditioning problems with a little strategic maintenance.

How our complimentary logs can help you head off air conditioning problems.

The better data you have on your system's performance, the better you're able to spot recurring problems and extend your equipment's useful life. HSB has created a complimentary air conditioning log to help you track operating characteristics and alert you to impending trouble.

Logs and checklists are available on HSB.com in the Equipment Care section.

Our log forms cover four groups of air conditioning and refrigeration installations: Systems with a reciprocating compressor under 25 horsepower, those with a reciprocating compressor over 25 HP, those with a centrifugal compressor, and absorption systems.

Note: Logs for larger systems feature categories for even more detailed record keeping. Complex systems require a complete set of readings either daily, at the beginning of each eight-hour shift, or, for major commercial buildings, every hour.

A. Annually check open or hermetic motors for burn out.

- Check air ventilation openings on open-type motors for obstruction.
- Check bearings on open-type motors for adequate and proper lubrication.
- Take insulation resistance readings on motor windings. If resistance is less than one megohm, don't start the motor. For hermetic motors, be sure the crank case heater is energized at least eight hours before this test.

B. Annually inspect motor controls.

- Remove covers on the motor's magnetic starters and examine the contacts. Compressor cycling can make them deteriorate. Look for pitting or corrosion.
- Check all terminal connections for tightness.
- Check the overload protection for defects and proper sizing
- Make sure timing devices have the correct operating sequence.
- Check mechanical linkage for binding and looseness.

C. Check the fans every month.

- Check fans for broken, cracked, bent or loose blades and hubs.
- Check the fan shaft and bearings.
- Check belt tension and condition.

D. Annually check the thermostatic expansion valve.

- Check the thermostat expansion valve every year. If it's not operating within its design limits, it can affect the safe operation of the equipment.

E. Check the operating safety valve every year.

- They're the heart of your equipment. Make sure they're properly calibrated and in working order.
- Immerse thermal sensing controls in a cold medium to verify the condition and setting of their sensing elements.
- Test oil pressure switches for mechanical and electrical malfunction. Flow switches should be removed from the well for examination, be sure to look for signs of corrosion on the paddle and linkage.

Hermetic air-cooled reciprocating system (25 HP)

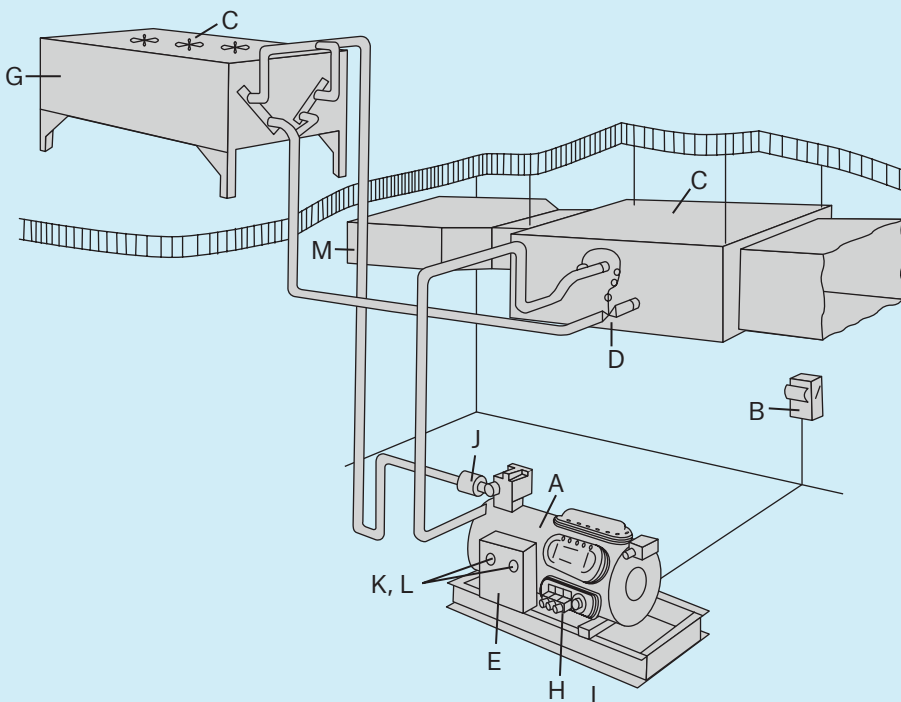

Typical 300-ton centrifugal system

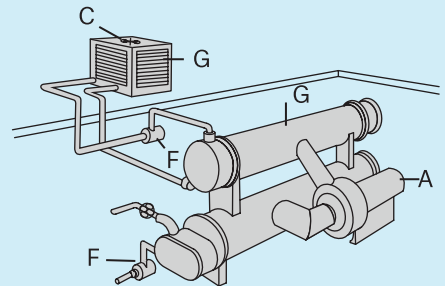

Open water-cooled reciprocating system (25 HP)

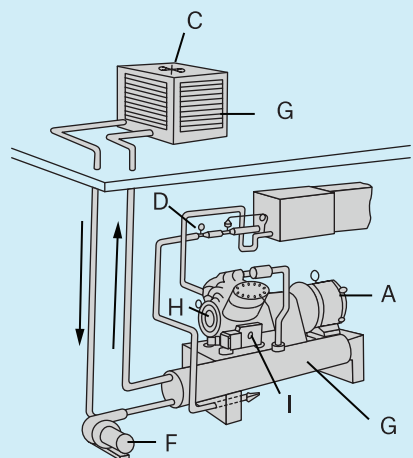

F. Check pumps every month.

- Check the condition of pump bearings, packings, shaft couplings and seals.

G. Clean the condensers/cooling towers every year.

- Clean air cooled condensers, but only with a solution marketed for this specific use. Take care to protect the fan motors from any moisture.
- Remove the heads on shell and tube condensers and clean the tubes of scale and debris.
- Clean the coils, sump, spray nozzles and overflow drain on evaporative condensers.
- For cooling towers, clean the sump and spray nozzles and check the baffles for tightness and soundness.
- Check the makeup water valve to be sure it's operating properly.

H. Help prevent 'scrambled' compressors.

- At least eight hours before start-up, hermetic compressors need to have their crank case heater energized. This step is vital. Preferably, leave the heaters energized for the rest of the season; when the compressor is idle, the heater will prevent refrigerant from migrating to the compressor.
- Have the cylinder heads removed and check the compressor valves—at least once every two years, or every 10,000 hours. Valve failure is one of the biggest causes of compressor break down. If you see signs of wear or fatigue, replace them. (Valves are relatively inexpensive.)

Avoid lubrication failure.

Lubrication failure is one of the biggest causes of equipment breakdown. Without proper lubrication at all times, moving parts in the motor-compressor wear out, overheat, burn and break.

Every year, have your service technician check the oil to make sure it's suitable: clean and non-acidic.

Also have the technician leak test the system regularly, and repair any point of leakage immediately.

I. Weekly check lubrication.

When the system is idle, look through the oil sight glass to check lubrication in the compressor crankcase. The oil level should remain constant. If you temporarily lose oil in the sight glass, you may have unwanted refrigerant in the crank case. Call the service technician at once.

Oil and refrigerant leaks often show up as oil spots with dust accumulations—a symptom of trouble.

Check these likely leak spots every week: compressor shaft seals • piping joints • coils • vessels • compressors • motors.

J. Avoid refrigerant circuit failure.

Moisture hurts any refrigeration system: Preventing proper lubrication, corroding or copper plating the moving parts, and freezing in the expansion valves. The result: Erratic performance, inefficiency, and even breakdown.

Moisture can enter the system if water-cooled condensers or water chillers leak. It can get in accidentally when you're charging refrigerant or oil into the system, unless you take special care. Here's how to check for moisture problems:

Equip your refrigerant circuit (liquid line) with a moisture sight glass indicator. Look for any change in the indicator chemical color. If the color changes toward 'wet', make sure your service technician corrects the problem, cleans and dries the system, and installs proper liquid and suction line filters and dryers.

It's even more important to determine the source of the moisture and to correct it right away. You may need to leak test any water-cooled condensers or chillers.

Normally, you'll see a pattern of clear liquid flow. If you notice other changes in the flow pattern (such as gas bubbles in the liquid refrigerant), have the system checked to see if it's properly charged with refrigerant. Control malfunction can also cause flow pattern changes.

Regularly check temperature (K) and pressure (I) controls.

Effective air conditioning depends on reliable temperature and pressure controls. Each is calibrated to perform a specific function. Periodically have them serviced, adjusted and proof-tested—only by qualified personnel.

When your system shuts down, check these areas.

Above-normal room temperatures invariably spell trouble. If there hasn't been a power interruption and all other checkpoints appear normal, call the service technician.

If the motor-compressor has shut down, don't attempt to restart the system. Protective controls may have tripped it off; find and correct the cause of the trip-off. Don't attempt to restart the system—it could result in severe equipment breakdown.

Don't attempt to adjust regulating or protective controls yourself: This is the time for an expert to diagnose and correct the problem.

To avoid pressure problems: Try to determine normal discharge and suction pressures. (Your air conditioning unit may be equipped with pressure gauges.) As with temperature changes, any increase in pressure is reason enough to call the service technician at once.

Dirty condensers are a key cause of pressure and temperature problems. Make sure the technician verifies that the condenser is clean. If you have a water-cooled or evaporate condenser, use an effective water treatment to prevent scale, corrosion and algae.

M. Keep air filters clean.

Keep air filters free of dust particles, smoke and dirt. Keep a careful log of cleaning dates to maintain an effective cleaning schedule.

If your system is an absorption unit: (not shown here) test and evaluate the lithium bromide solution concentration and the lithium bromide inhibitor.

Check the absorption purge unit and purge system for proper operation.

Examine all canned motor pumps used on the absorber unit and check the bearings for wear. Look carefully at the condition of the motor stator and rotor seals.

These diagrams can help you work with service people to identify parts needing replacement, points of refrigerant leakage, regulating and protective control settings, and other critical features.

If operating characteristics change—watch out.

Each system has its own normal pattern of noise, vibration, speed, temperature and pressure. They vary, depending on the season and the heat load your system handles. Once you've familiarized yourself with these normal conditions, you'll be able to spot trouble signs.

Any change in normal operating characteristics is a warning. Call the service technician if you notice:

- unusual noise or vibration
- a strange odor
- oil or water spots
- sudden changes in temperature, speed or pressure.

Correct the problem at once.

Suspect a problem? Call your service firm.

That's critical advice. Consult with a professional before undertaking any maintenance steps or repairs. An adequate service program may cost a little more up front, but it will pay off in long-term savings.

Our advice is intended to complement the equipment manufacturers' recommendation—not replace them. If you have doubts about any particular procedure, call an air conditioning service firm.

Air Conditioning/Refrigeration Maintenance/Operations Guide

Manufacturer: _____ Number: _____

Size: _____ Location: _____

Service Company: _____

Service Technician: _____

Date Serviced: _____